

FEATURES

- Available as "HR" (high reliability) screened per MIL-PRF-19500, JANTX level. Add "HR" suffix to base part number.
- Available as non-RoHS (Sn/Pb plating), standard, and as RoHS by adding "-PBF" suffix.

MAXIMUM RATINGS

Part number	Maximum repetitive peak reverse voltage	Maximum direct reverse voltage	Maximum average reverse current at maximum rated $I_{F(AV)}$ and V_{RRM}
	$T_C = -65^\circ \text{ to } +200^\circ \text{C}$	$T_C = -65^\circ \text{ to } +200^\circ \text{C}$	$T_C = 150^\circ \text{C}$
	V	V	mA
1N3111	50	40	25
1N3085	100	80	25
1N3086	200	160	17
1N3087	300	240	17
1N3088	400	320	17
1N3089	500	400	17
1N3090	600	480	17
1N3091	800	640	16
1N3092	1000	800	12
1N5162	1200	960	10

ELECTRICAL CHARACTERISTICS ($T_A = 25^\circ \text{C}$ unless otherwise specified)

Characteristic	Symbol	1N3111, 1N3085, 1N5162 SERIES	Unit	Test Condition
Maximum average forward current	$I_{F(AV)}$	150	A	180° sinusoidal conduction max. $T_C = 150^\circ \text{C}$
Maximum peak one-cycle non-repetitive surge current	I_{FSM}	2850	A	Half cycle 50Hz sine wave or 6ms rectangular pulse
		3000		Half cycle 60Hz sine wave or 5ms rectangular pulse
		3400		Half cycle 50Hz sine wave or 6ms rectangular pulse
		3550		Half cycle 60Hz sine wave or 5ms rectangular pulse
Maximum I^2t for fusing	I^2t	41000	A ² s	$t = 10\text{ms}$
		37500		$t = 8.3\text{ms}$
		58000		$t = 10\text{ms}$
		53000		$t = 8.3\text{ms}$
Maximum I^2vt for individual fusing	I^2vt	580000	A ² vs	$t = 0.1$ to 10ms , $V_{RRM} = 0$ following surge
Maximum peak forward voltage	V_{FM}	1.2	V	$I_{F(AV)} = 150\text{A}$, $T_C = 150^\circ \text{C}$
Maximum operating case temperature range	T_C	-65 to +200	°C	

ELECTRICAL CHARACTERISTICS ($T_A = 25^\circ\text{C}$ unless otherwise specified)

Characteristic	Symbol	1N3111, 1N3085, 1N5162 SERIES	Unit	Test Condition
Maximum storage temperature range	T_{stg}	-65 to +200	$^\circ\text{C}$	
Maximum internal thermal resistance, junction to case	R_{thjc}	0.25	$^\circ\text{C}/\text{W}$	DC operation
Thermal resistance, case to sink	R_{thcs}	0.10	$^\circ\text{C}/\text{W}$	Mounting surface flat, smooth, greased

MECHANICAL CHARACTERISTICS

Case	DO-8(R)
Marking	Alpha-numeric
Normal polarity	Cathode is stud
Reverse polarity	Anode is stud (add "R" suffix)

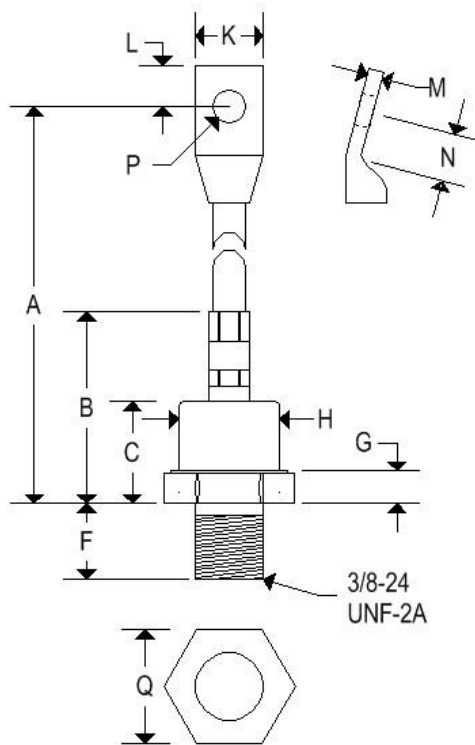

	DO-8(R)			
	Inches		Millimeters	
	Min	Max	Min	Max
A	3.875	4.625	98.430	117.470
B	-	1.675	-	42.540
C	0.875	0.960	22.230	24.380
F	0.605	0.645	15.370	16.380
G	0.125	0.500	3.180	12.700
H	-	1.063	-	27.000
K	0.437	0.650	11.100	16.510
L	0.297	-	7.550	-
M	0.050	0.160	1.270	4.060
N	0.300	-	7.620	-
P	0.250	0.310	6.350	7.870
Q	1.031	1.063	26.190	27.000

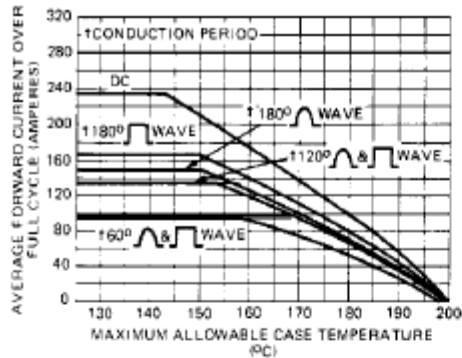

Fig. 1 - Average Forward Current Vs. Maximum Allowable Case Temperature

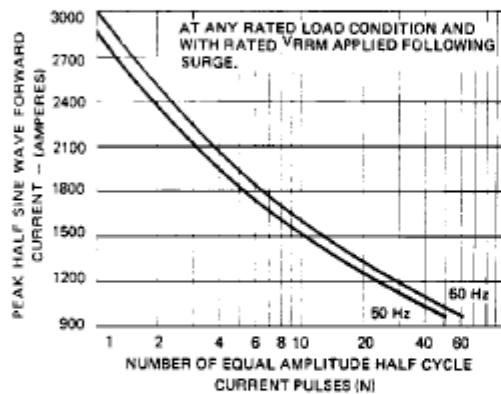

Fig. 3 - Maximum Non-Repetitive Surge Current Vs. Number of Current Pulses

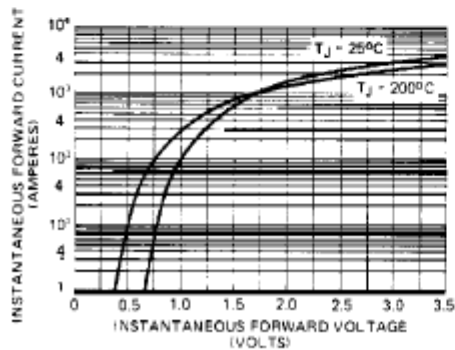

Fig. 4 - Maximum Forward Voltage Vs. Forward Current

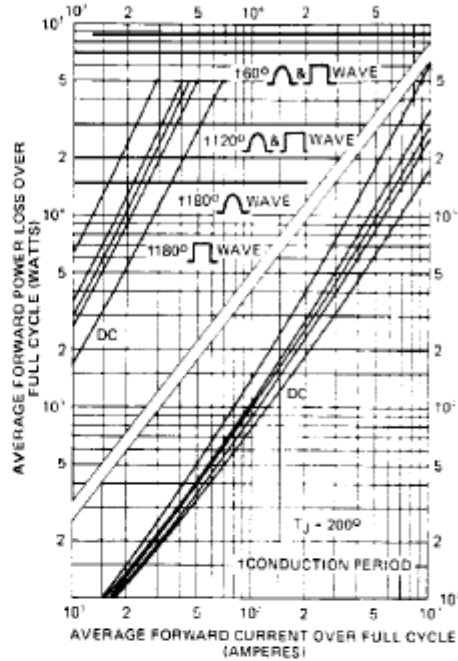

Fig. 2 - Maximum Forward Power Loss Vs. Average Forward Current

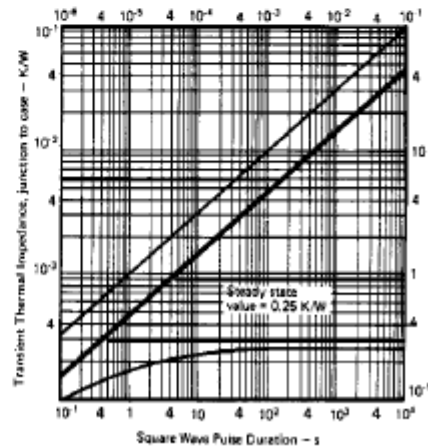

Fig. 5 - Maximum Transient Thermal Impedance, Junction-to-Case Vs. Pulse Duration